

**SIDING WINYLOWY / VINYLOVÝ SIDING / VINYLOVÉ DOSKY /  
VINILO SAIDINGAS / VINILA SAIDINGS / VINÜÜLVOODER**

SV(P/TP/PU)-01/05, SV-02  
SYSTEM MAX-3 SX(P/PU)-05

PL / CZ / SK / LT / LV / ET









# PANELE I LIŠTVY WYKOŃCZENIOWE • PANELE A DOKOŃČOVACÍ LIŠTY • PANELEY A LIŠTY NA FINÁLNU ÚPRAVU • PANELIAI IR APDAILOS LENTJUOSTĖS • APDARES PANEĖLI UN LĪSTES • PANEELID JA VIIMISTLUSLIISTUD

SV(P/TP/PU)-01

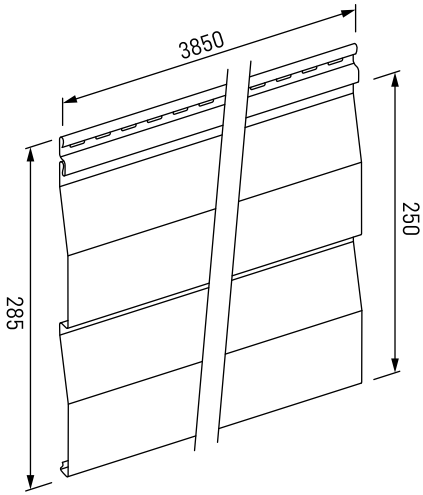

SV-02

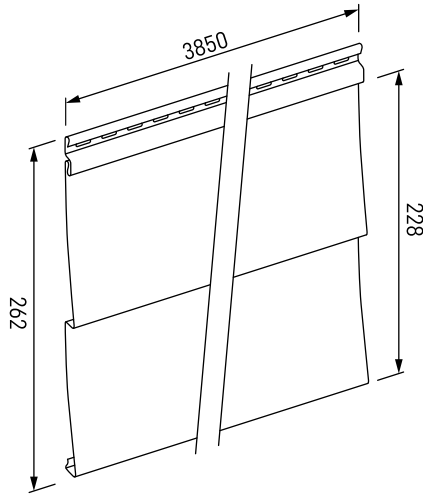

SV(P/TP/PU)/ SX(P/PU)-05

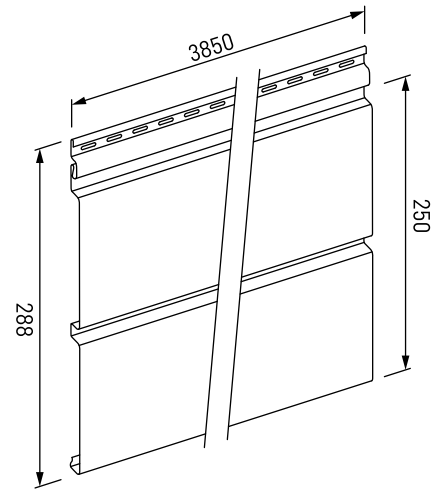

SV-11

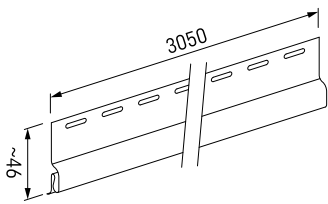

SV-11,5

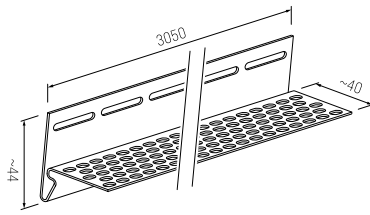

SV(P/PU)-12

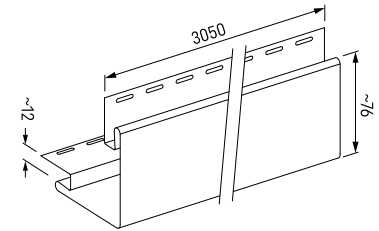

SV(P/PU)-13

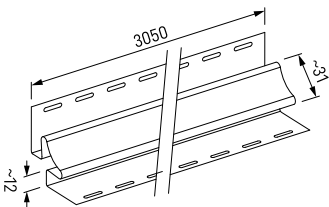

SV(P/PU)-14

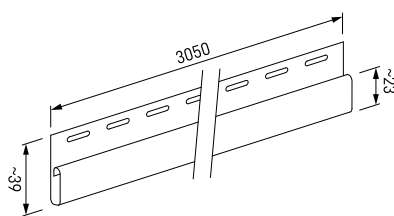

SV(P/PU)-15

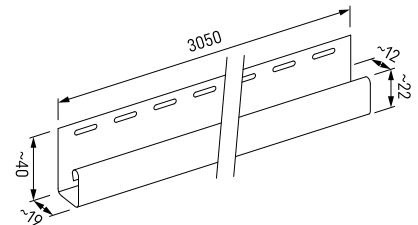

SV-16

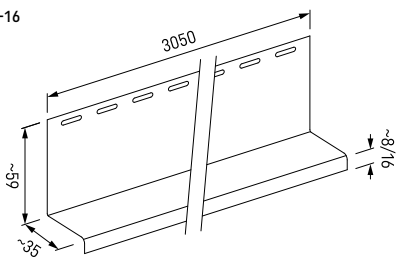

SV-17

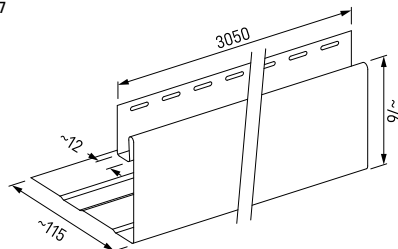

SV(P/PU)-18

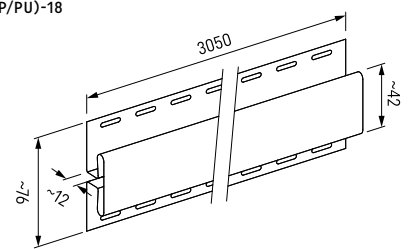

SV-19

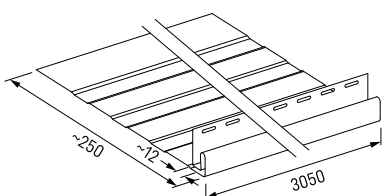

SV-20

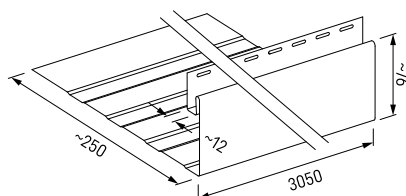

# NARZĘDZIA • NÁŘADÍ • NÁRADIE • ĮRANKIAI • INSTRUMENTI • TÖÖRIISTAD

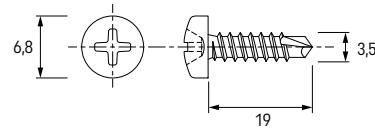
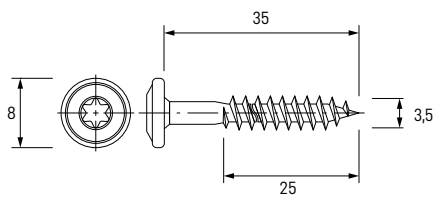
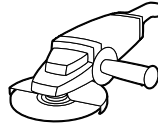
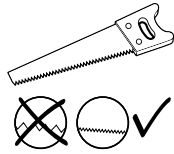
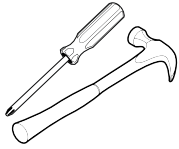
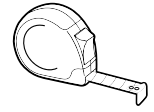
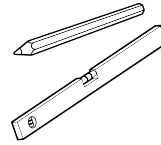
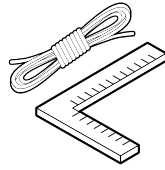

PL | wkręty do montażu na konstrukcji drewnianej  
 CZ | vřuty pro montáž na dřevěné konstrukci  
 SK | montážne skrutky na drevenej konštrukcii  
 LT | varžtai montavimui ant medinės konstrukcijos  
 LV | skrūves, kas paredzētas montāžai uz koka konstrukcijas  
 EE | kruvid puitkonstruktsioonile paigaldamiseks

PL | wkręty do montażu na konstrukcji metalowej  
 CZ | vřuty pro montáž na kovové konstrukci  
 SK | montážne skrutky na kovovej konštrukcii  
 LT | varžtai montavimui ant metalinės konstrukcijos  
 LV | skrūves, kas paredzētas montāžai uz metāla konstrukcijas  
 EE | kruvid metallkonstruktsioonile paigaldamiseks

## INFORMACJA O DYŁACJI • INFORMACE O DILATAČNÍCH SPÁRÁCH • INFORMÁCIE O ROZŠÍRENIE • INFORMACIJA APIE DILATACIJA • INFORMĀCIJA PAR DILATĀCIJAS ŠUVI • TEAVE DILATATSIOON

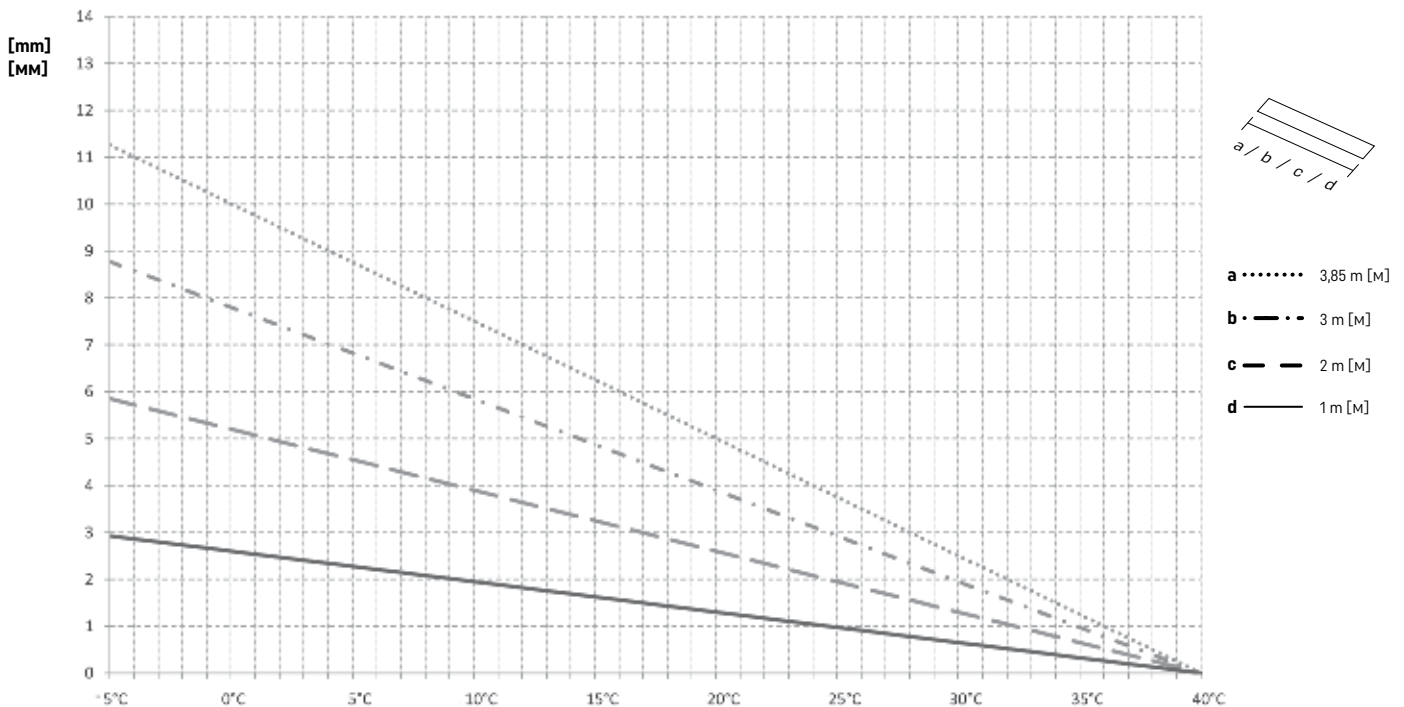

# 1. KONSTRUKCJA NOŚNA DREWNIANA • DŘEVĚNÁ NOSNÍ KONSTRUKCE • DREVENÁ NOSNÁ KONŠTRUKCIA • LAIKANTI MEDINĚ KONSTRUKCIJA • KOKA NESĚJKONSTRUKCIJA • KANDEV PUITKONSTRUKTSIOON

1.1

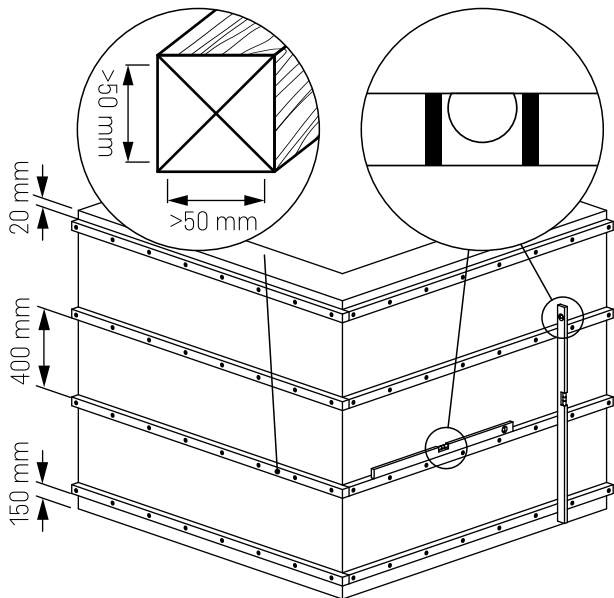

1.2

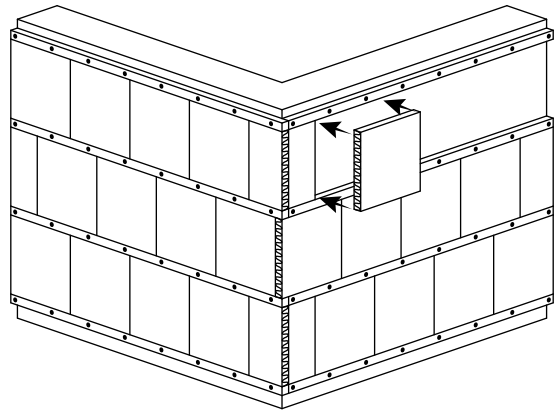

1.3

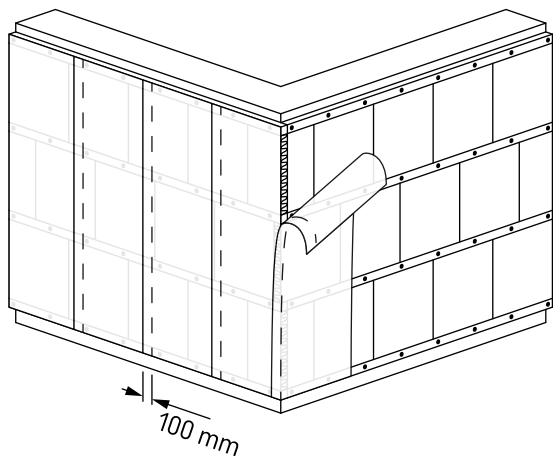

1.4

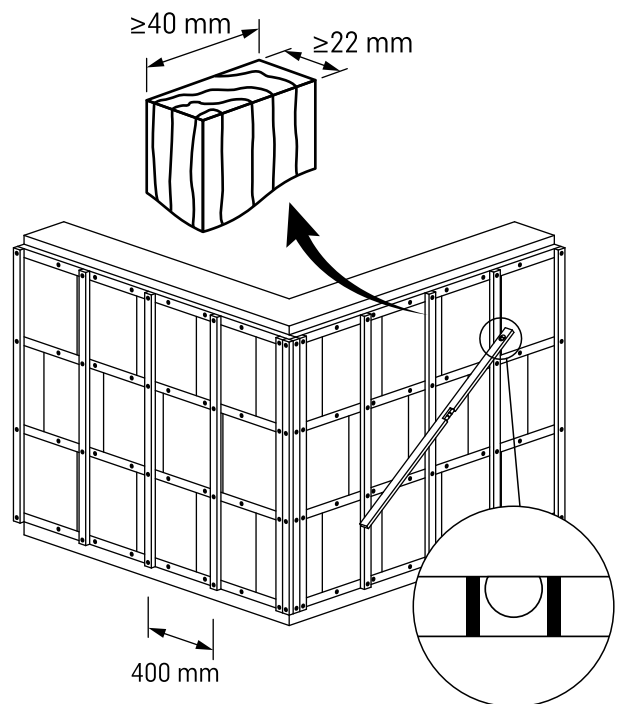

## 2. KONSTRUKCJA NOŚNA METALOWA • KOVOVÁ NOSNÁ KONSTRUKCE • KOVOVÁ NOSNÁ KONŠTRUKCIA • LAIKANTI METALINĖ KONSTRUKCIJA • METÄLA NESĚJKONSTRUKCIJA • KANDEV PUITKONSTRUKTSIOON

2.1

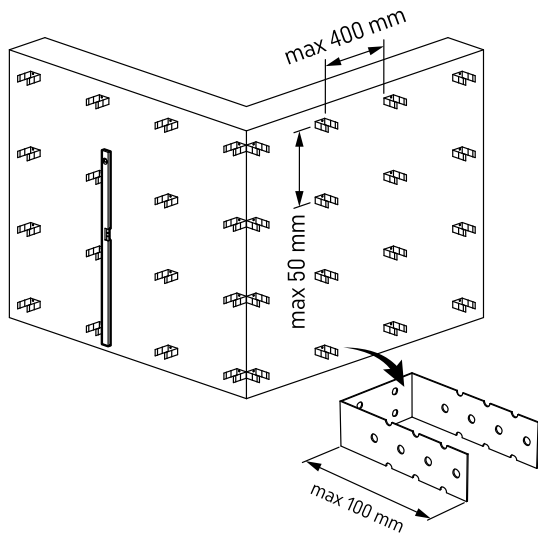

2.2

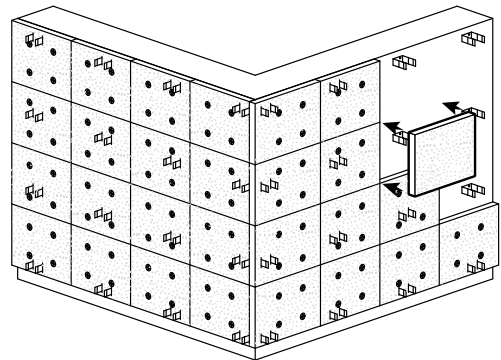

2.3

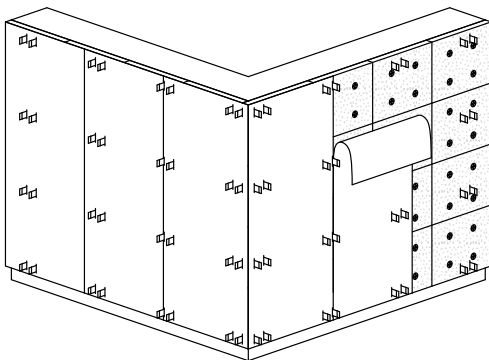

2.4

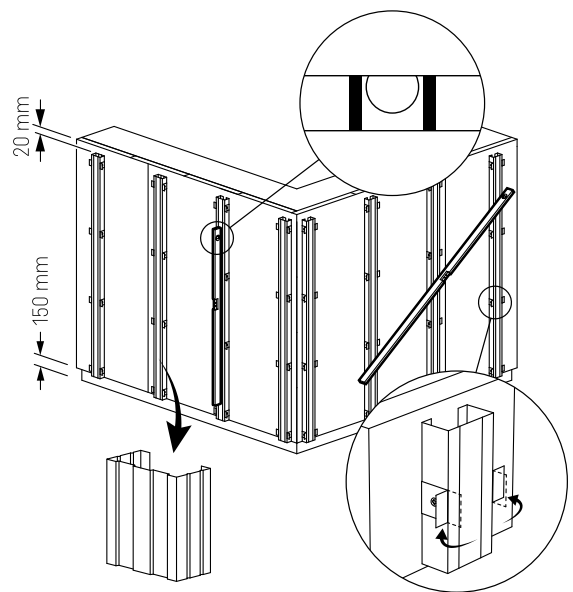

2.5

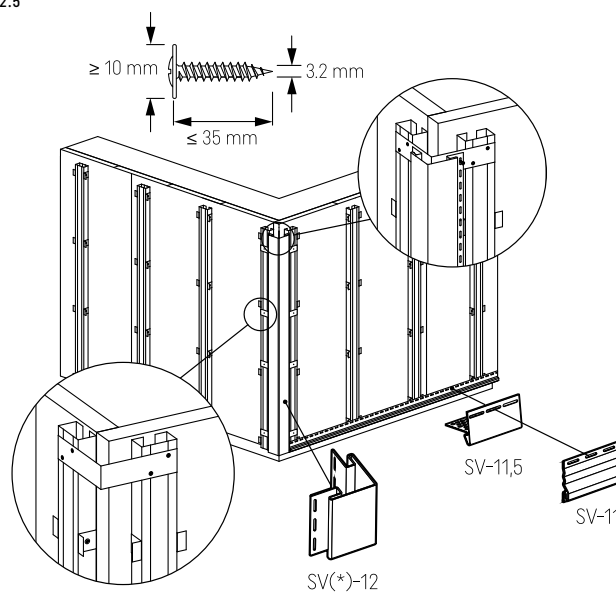



2.6

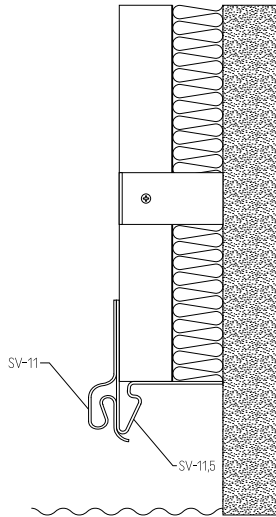

2.7

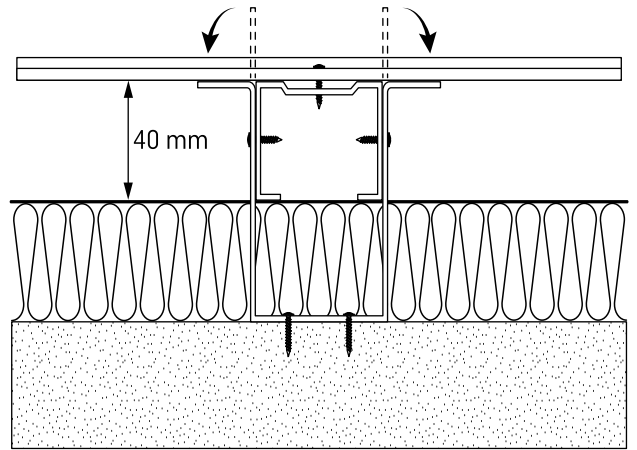

### 3. ETAPY MONTAŽU • MONTÁŽNÍ POSTUP • ETAPY MONTÁŽE • MONTAVIMO ETAPAI • MONTĀŽAS POSMI • PAIGALDUSE ETAPID

3.1

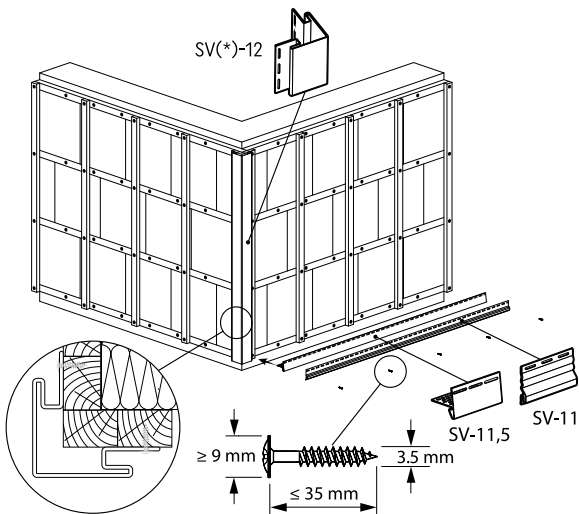

3.2

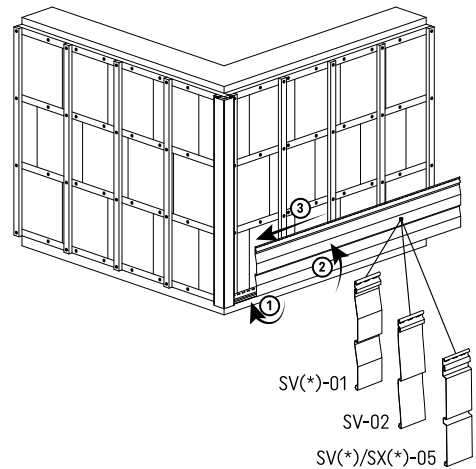

3.3

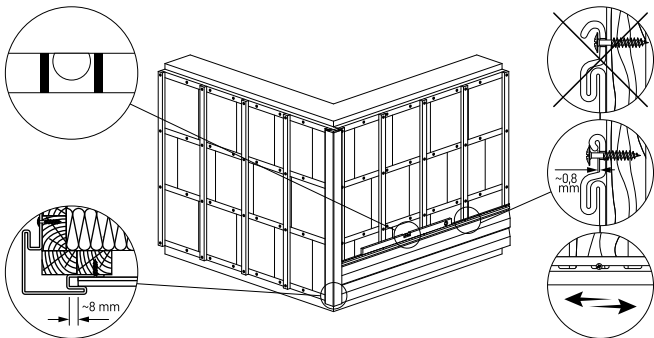

3.4

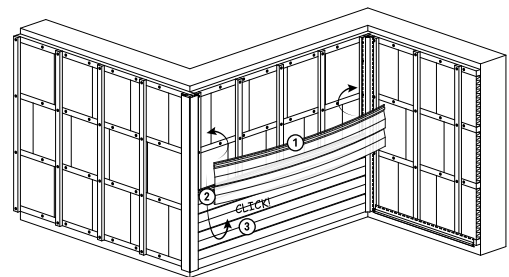

3.5

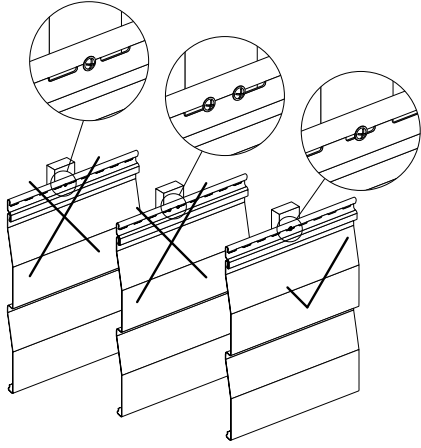

3.6

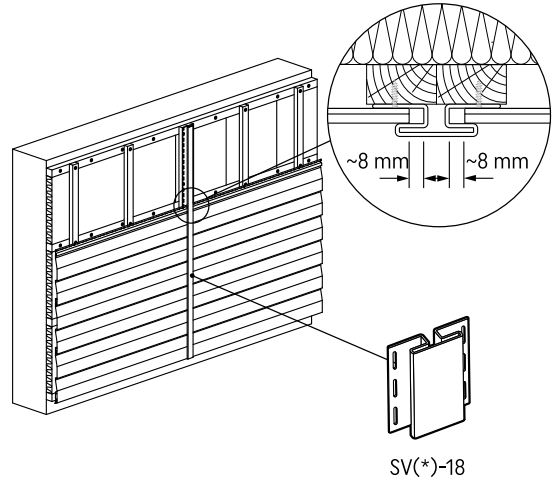

3.7

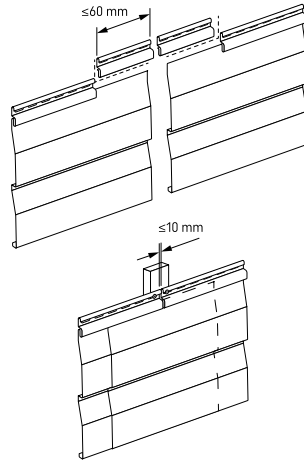
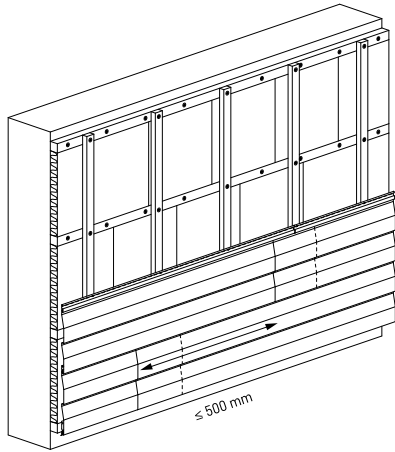

3.8

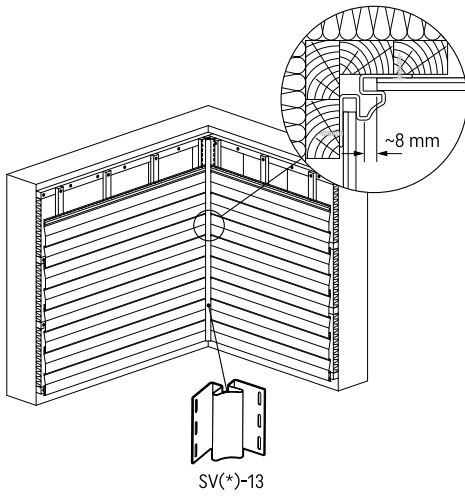

3.9

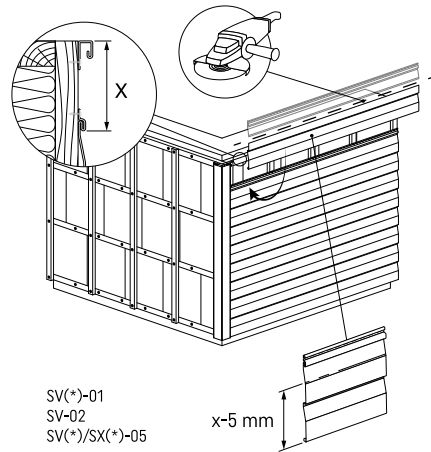

3.10

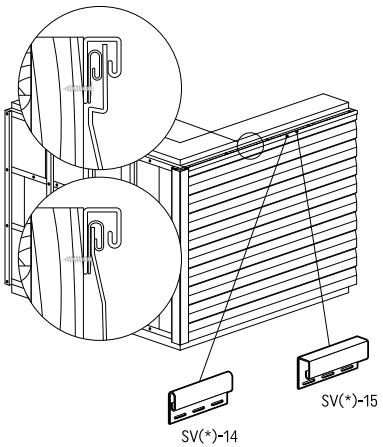

3.11

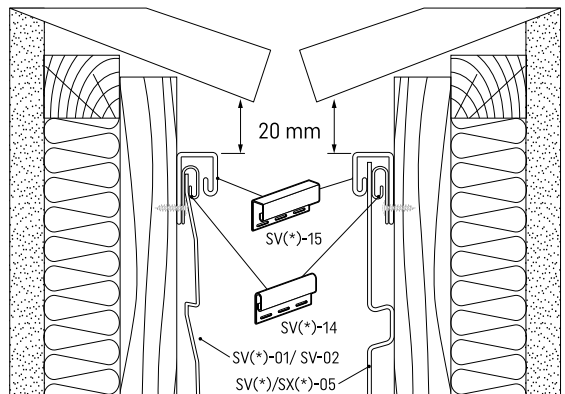

**4. ETAPY MONTAŻU – OKNA, DRZWI • MONTÁŽNÍ POSTUP – OKNA, DVEŘE •  
 ETAPY MONTÁŽE – OKNA, DVEŘE • MONTAVIMO ETAPAI – LANGAI, DURYS •  
 MONTĀŽAS POSMI – LOGI, DURVIS • PAIGALDUSE ETAPID – AKNAD, UKSED**

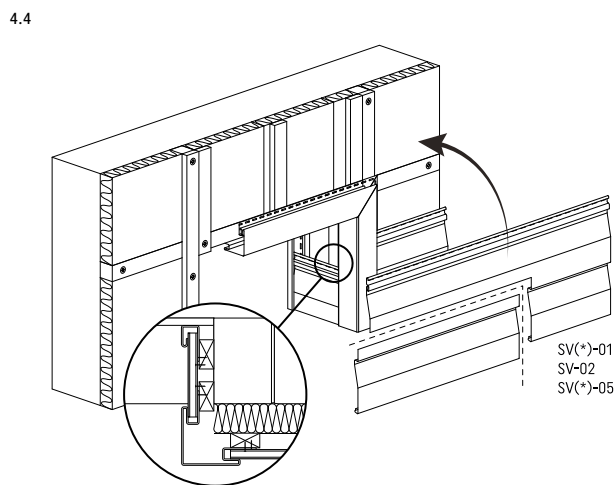
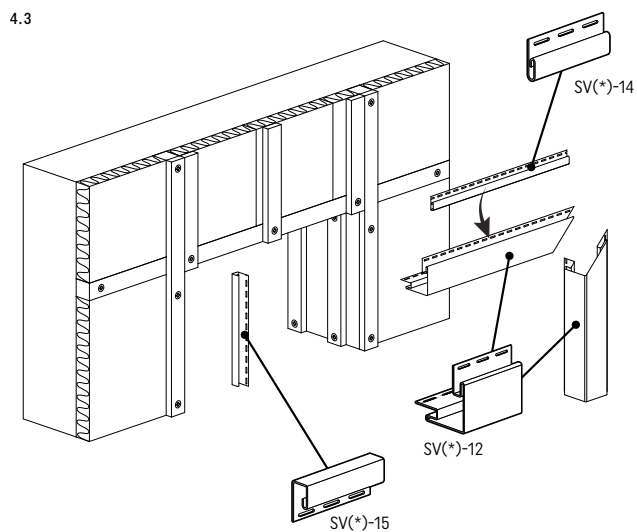
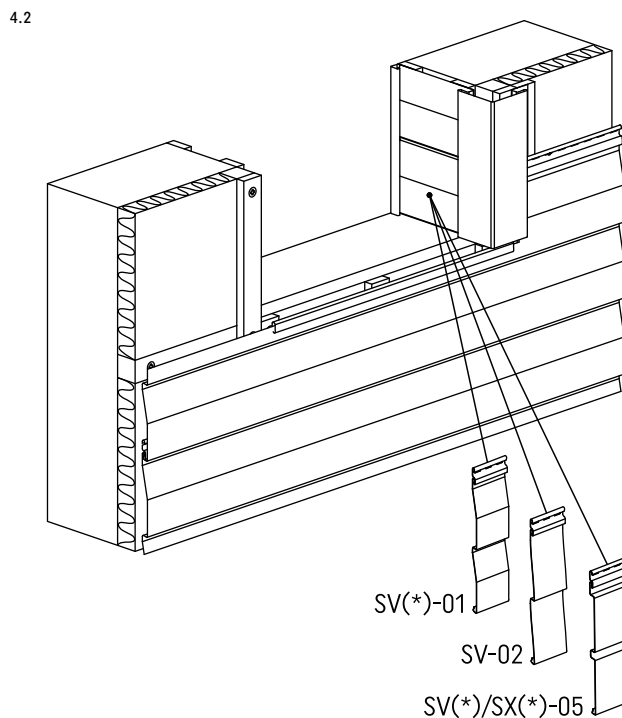
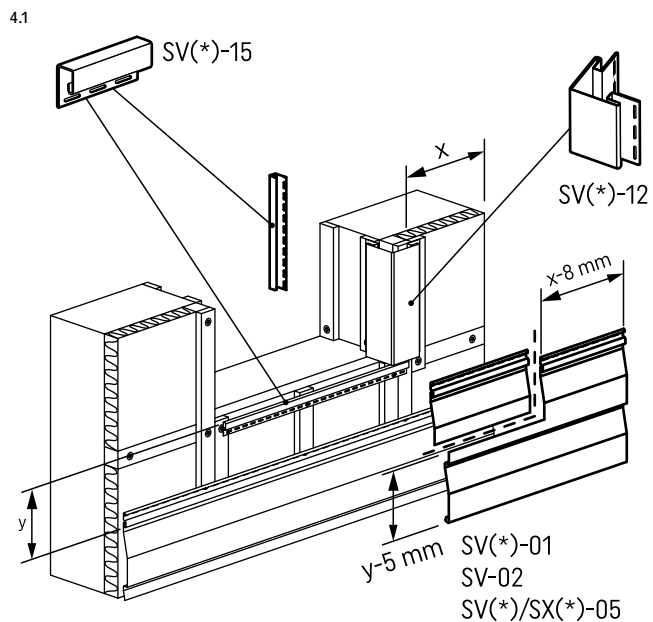

# 5. MONTAŽ PIONOWY • SVISLÁ MONTÁŽ • VERTIKÁLNA MONTÁŽ • VERTIKALUS MONTAVIMAS • VERTIKĀLĀ MONTĀŽA • VERTIKAALNE PAIGALDUS

5.1

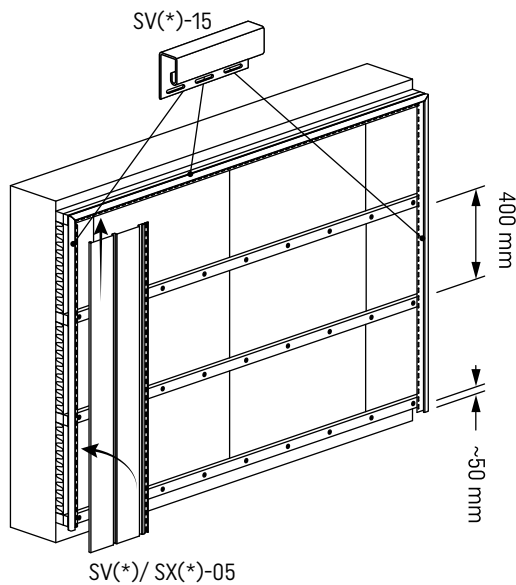

5.2

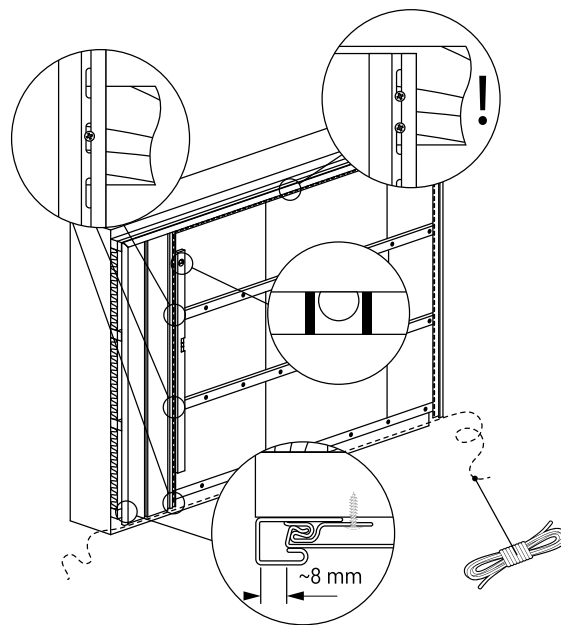

5.3

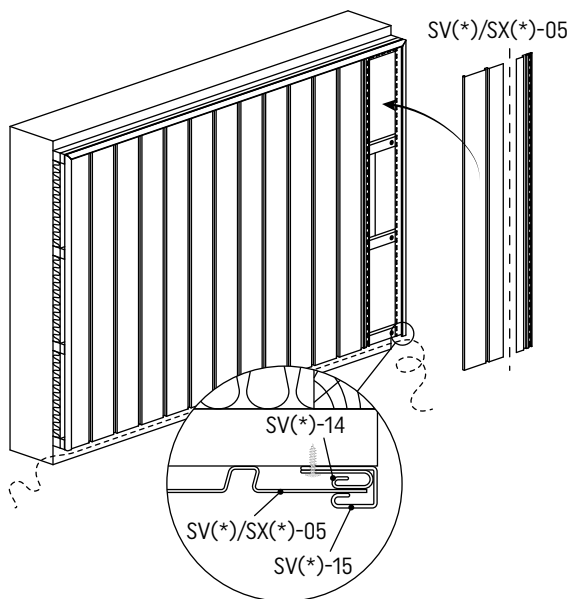

5.4

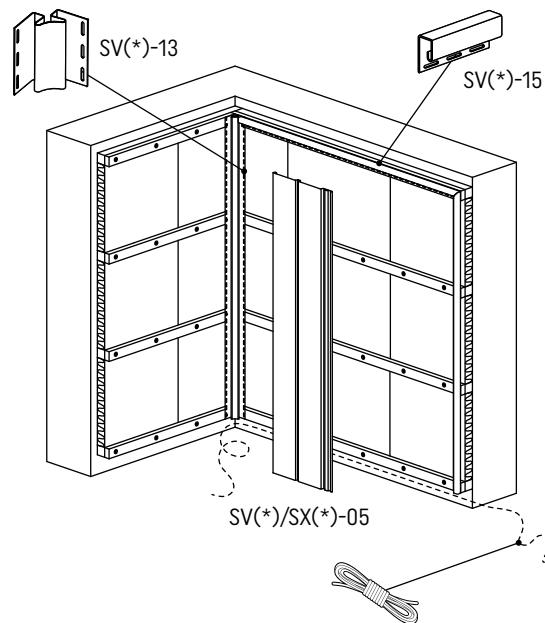

5.5

